

DESCRIPTION

The 8263/8264 3-Input, 4-Bit Multiplexer is a gating array whose function is analogous to that of a 4-pole, 3-position switch. Four bits of digital data are selected from one of three inputs. A 2-bit channel-selection code determines which input is to be active.

The Data Complement input controls the conditional complement circuit at the Multiplexer output to effect either inverting or non-inverting data flow.

The 8263 employs active output structures to effect minimum delays: the 8264 utilizes bare collector outputs for expansion of input terms.

The 8264 may be expanded by connecting its outputs to the outputs of another 8264. Provision is made for use of a 3-bit code to determine which Multiplexer is selected; thus, eight Multiplexers may be commoned to effect a 4-pole, 24-position switch.

PIN CONFIGURATIONS

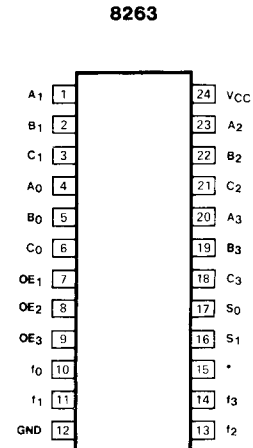

Figure A

ORDERING CODE (See Section 9 for further Package and Ordering Information)

| PACKAGES | PIN CONF. | COMMERCIAL RANGES | MILITARY RANGES |
|-------------|-----------|--|---|
| | | V _{CC} =5V ± 5%; T _A =0°C to +75°C | V _{CC} =5V ± 5%; T _A =-55°C to +125°C |
| Plastic DIP | Fig.A | N8263N | |
| | Fig.B | N8264N | |
| Ceramic DIP | Fig.A | N8263F | S8263F |
| | Fig.B | N8264F | S8264F |
| Flatpak | Fig.A | | S8263Q |
| | Fig.B | | S8264Q |

TRUTH TABLE

| DATA INPUT | | | CHANNEL SELECT | | DATA COMPLEMENT | OUTPUT ENABLE (8264) | DATA OUTPUTS |
|----------------|----------------|----------------|----------------|----------------|-----------------|----------------------|----------------|
| A _n | B _n | C _n | S ₀ | S ₁ | | | |
| A _n | X | X | H | H | L | H | A _n |
| X | B _n | X | L | H | L | H | B _n |
| X | X | C _n | H | L | L | H | C _n |
| X | X | X | L | L | L | H | 0 |
| A _n | X | X | H | H | H | H | \bar{A}_n |
| X | B _n | X | L | H | H | H | \bar{B}_n |
| X | X | C _n | H | L | H | H | \bar{C}_n |
| X | X | X | L | L | H | H | H |
| X | X | X | X | X | X | L | H |

H = HIGH
L = LOW
X = Don't care

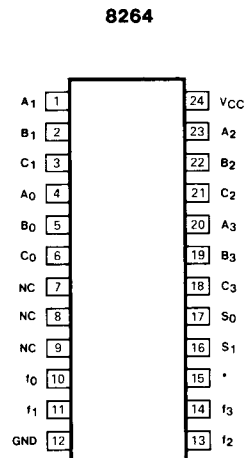
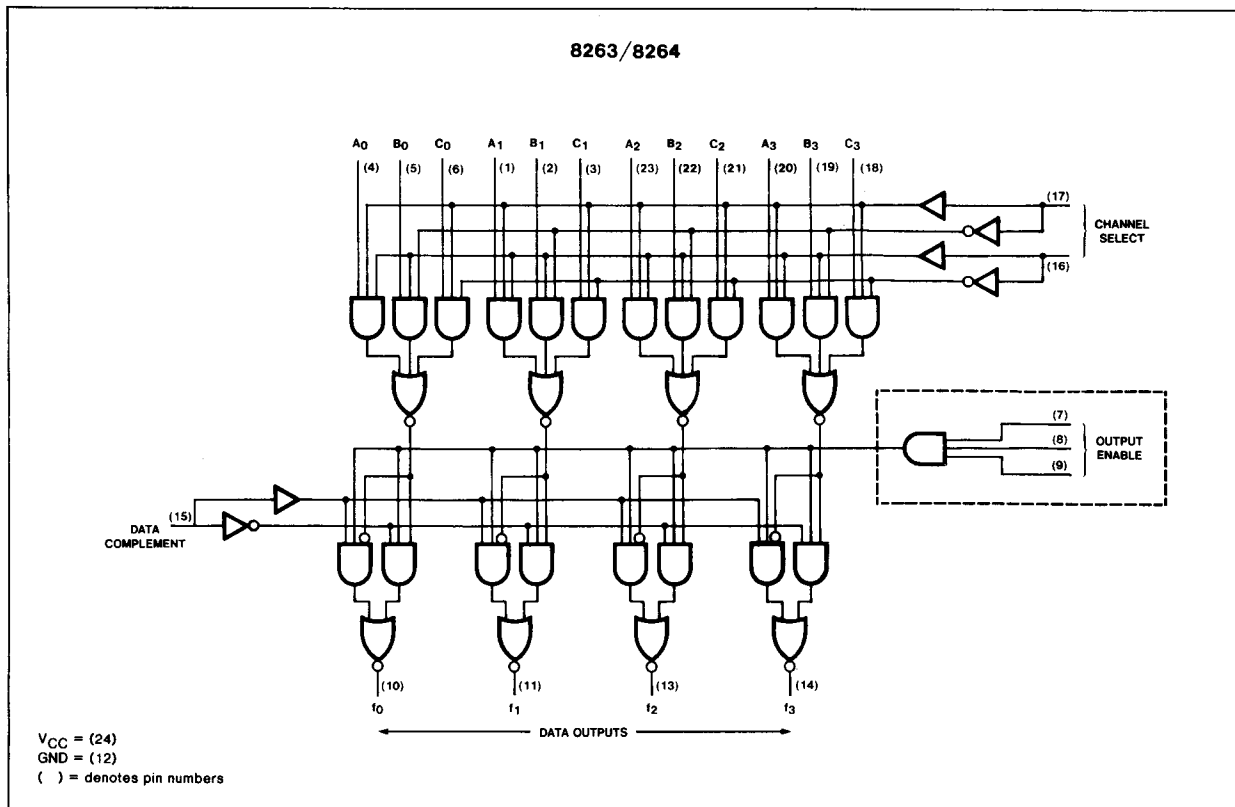

Figure B

*Data complement

LOGIC DIAGRAM



DC ELECTRICAL CHARACTERISTICS

| PARAMETER | TEST CONDITIONS | 8263 | | 8264 | | UNIT |
|---------------------------------------|--|------|--------------|------|--------------|--------------------|
| | | Min | Max | Min | Max | |
| V_{OH} Output HIGH voltage | $V_{CC} = 4.75V, I_{OH} = -800\mu A$ | 2.6 | | | | V |
| I_{OH} Output HIGH current | $V_{CC} = 4.75V, V_{OUT} = 2.0V$ | | | | 200 | μA |
| V_{OL} Output LOW voltage | $V_{CC} = 4.75V, I_{OL} = 9.6mA$ 8263 8264 | | 0.4 | | 0.4 | V |
| I_{IL} Input LOW current | $V_{CC} = 5.25V, V_{IN} = 4.5V$ | | -1.6 -3.2 | | -1.6 -3.2 | mA mA |
| I_{IH} Input HIGH current | $V_{CC} = 5.25V, V_{IN} = 4.5V$ | | 40 80 | | 40 80 | μA μA |
| I_{OS} Output short circuit current | $V_{CC} = 5V, V_{OUT} = 0V$ | -20 | -70 | | | mA |
| I_{CC} Supply current | $V_{CC} = 5.25V$ | | 80 | | 90.4 | mA |

AC CHARACTERISTICS: $T_A = 25^\circ\text{C}$ (See Section 4 for Waveforms and Conditions)

| PARAMETER | TEST CONDITIONS | 8263 | | 8264 | | UNIT |
|--------------------------------------|--|--|----------|---|----------|----------|
| | | $C_L = 18\text{pF}$ $R_1 = \infty\Omega$ $R_2 = 150\Omega$ | | $C_L = 30\text{pF}$ $R_1 = 360\Omega$ $R_2 = 440\Omega$ | | |
| | | Min | Max | Min | Max | |
| t _{PLH} t _{PHL} | Propagation delay A_n to f_n | | 26 26 | | 36 36 | ns ns |
| t _{PLH} t _{PHL} | Propagation delay S_0, S_1 to f_n | | 36 36 | | 36 36 | ns ns |
| t _{PLH} t _{PHL} | Propagation delay DC to f_n | | 26 26 | | 30 30 | ns ns |
| t _{PLH} t _{PHL} | Propagation delay OE to f_n | | | | 30 30 | ns ns |

NOTE

b. For family dc characteristics, see inside front cover for 54/74 and 54H/74H, and see inside back cover for 54S/74S and 54LS/74LS specifications.

AC WAVEFORMS

